

Please go to www.quoise.com for product cleaning tips. Go to the **Care + Maintenance** selection.

Tools Required: Flathead screwdriver, Phillips screwdriver, pliers, wire cutters, wire strippers, electrical tape, safety glasses.

Light Source: (3) Candelabra Base 60W Maximum

Estimated Assembly Time: 20-30 minutes

Preparation: Identify and inspect all parts before beginning installation. Check package content list and diagrams below to be sure all parts are present. If any parts are missing or damaged, do not attempt to assemble, install, or operate the fixture. Contact customer service for replacement parts.



Warnings and Cautions

Turn off electricity at circuit breaker or main fuse box before installation. Consult a licensed electrician if in doubt.

These instructions are provided for your safety. It is very important you read them completely before installing the fixture. We strongly recommend that a licensed, professional electrician perform the installation.

Disconnect fixture from power source before replacing bulbs. Make sure bulbs are given sufficient time to cool before removal. Do not subject glass parts to any shock while in operation or shattering may result.

Package Contents

Part	Description	Quantity
A	Mounting Screw	3 pcs.
B	Finial Assembly	1 pc.
C	Fixture Body	1 pc.
D	Large Glass Panel	4 pcs.
E	Lock Screw	8 pcs.
F	Tab	8 pcs.
G	Small Glass Panel	4 pcs.

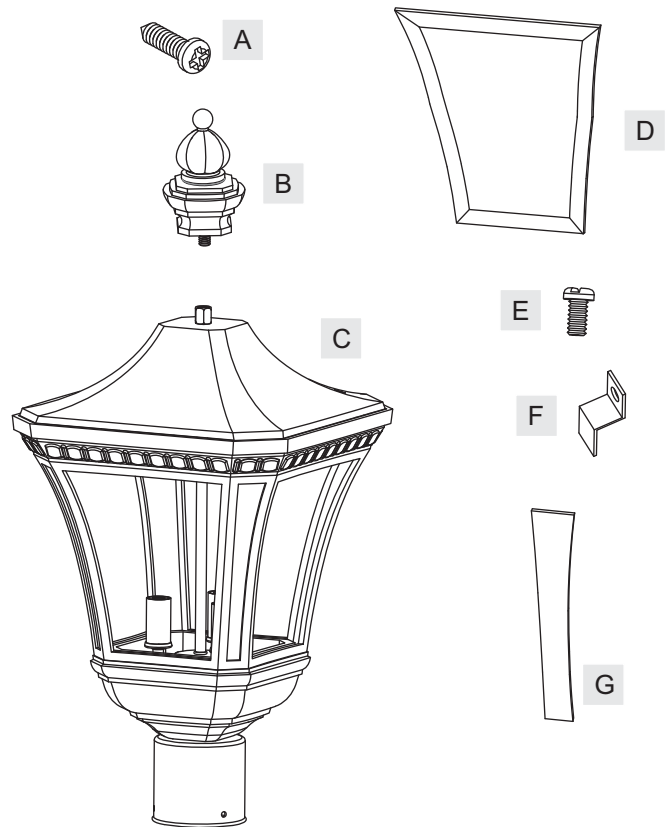

Thank you for purchasing a Quozel product.

Need assistance with parts or assembly? Call Quozel customer service at 1-631-273-2700
 or visit us on-line at www.quoise.com

DE9256IB

FINISH: IMPERIAL BRONZE

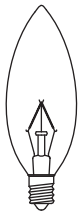
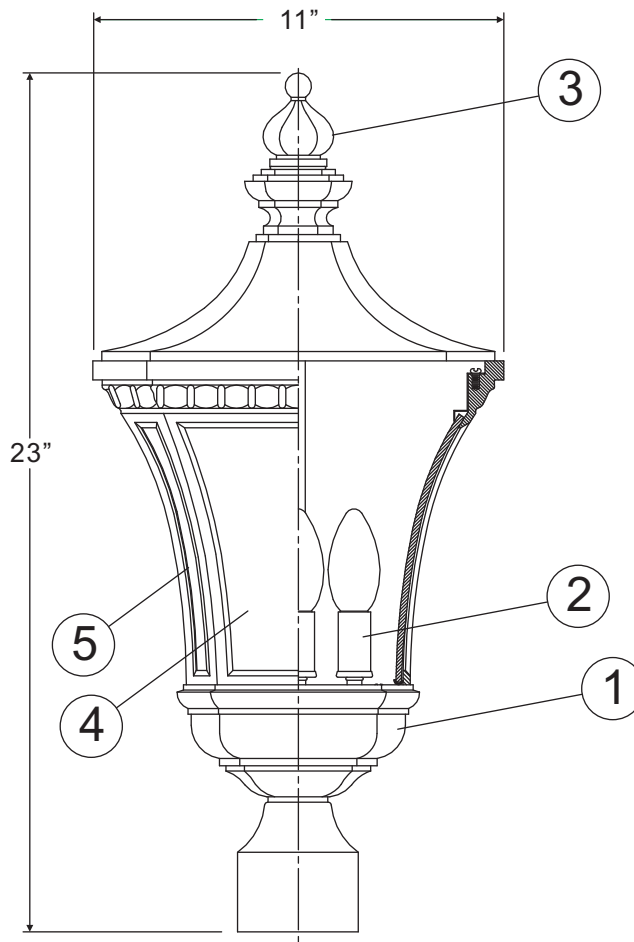
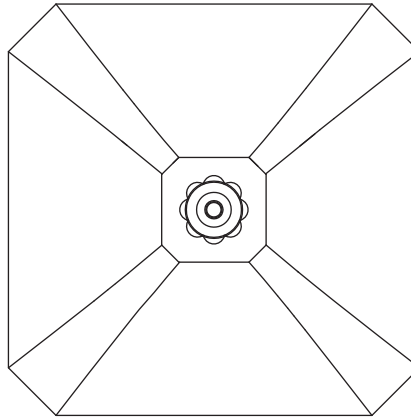

(3)60W candelabra
base bulbs
(not Supplied)

NOTE: ALL DIMENSIONS ARE ROUNDED UP TO THE NEAREST 1/2"

NO.	PART NUMBER	REPLACEMENT PART DESCRIPTION	REQ.
1	19256IBDE	BASE IMPR BRNZ DE9256IB	1
2	M380CCIB	CDCV IMPBRZ REPL CANDLE COVER	3
3	M388FIIB	FINL IMPBRZ REPL DE8960/8961IB	1
4	G1200PA	PANL LRG CLR BEV REPL DE8960IB	4
5	G1199PA	PANL SML CLR BEV REPL DE8960IB	4

STEP 1 – Remove Fixture Hood from Glass Frame

- A. Remove the Fixture Hood from the Frame by unscrewing the Hex Coupling.

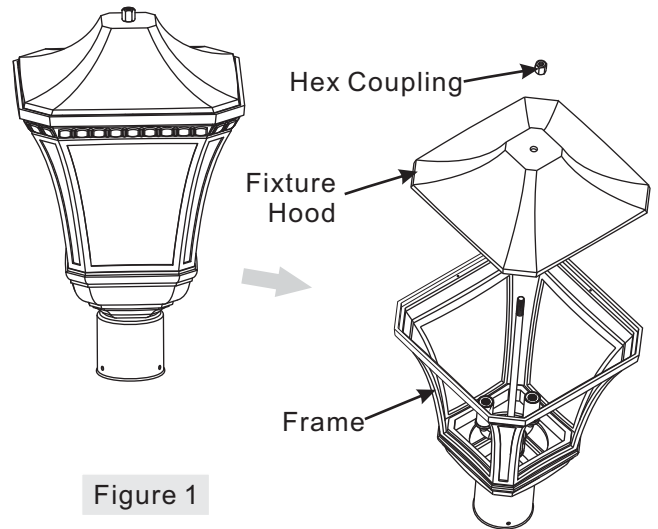

STEP 2 – Attach Glass

- A. Slip Large Glass Panels (D) and Small Glass Panels (G) inside of the Fixture Frame as shown. Locate Tabs (F) onto the top edge of Large Glass Panels (D) and Small Glass Panels (G). Line up holes on Tabs onto Mounting Holes in the Fixture Frame. Thread Lock Screws (E) into mounting holes and hand tighten until snug to secure the Glass Panels.

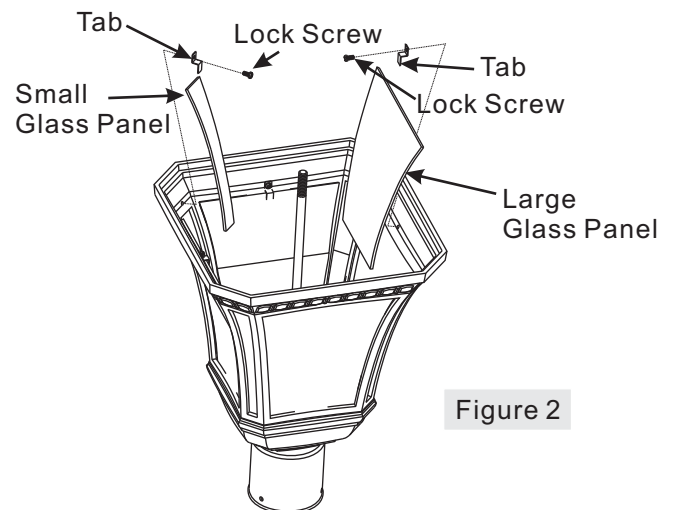

STEP 3 – Drill Pilot Holes on Post

- A. Carefully fit the Post Fitter over the end of the Post (not supplied), making sure the Post Fitter is fully seated.
B. Mark the drill point for the (3) Mounting Screws, using (3) Mounting Holes as reference. After marking hole locations, remove fixture from post and drill 1/16" pilot holes for screws.

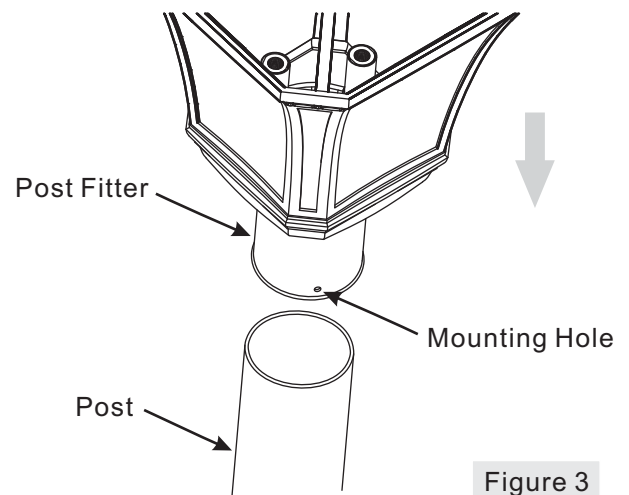

Thank you for purchasing a Quoizel product.
Need assistance with parts or assembly? Call Quoizel customer service at 1-631-273-2700
or visit us on-line at www. quozel. com

STEP 4 – Make Wire Connections

- Use standard wire connectors to make all wire connections. (Connectors are not included with fixture.) Strip and prepare wire ends according to instructions supplied with connectors.
- Connect White Supply Wire from the Post to White Wire from fixture.
- Connect Black (or Red) Supply Wire from the Post to Black Wire from fixture.
- Connect Ground Wire from the Post to Ground Wire from fixture.
- Twist connectors until wires are tightly joined together.
- Wrap each connection with approved electrical tape and carefully stuff all the connected wires into the Post.

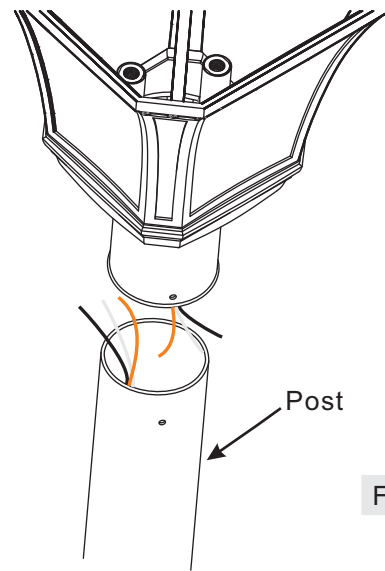

Figure 4

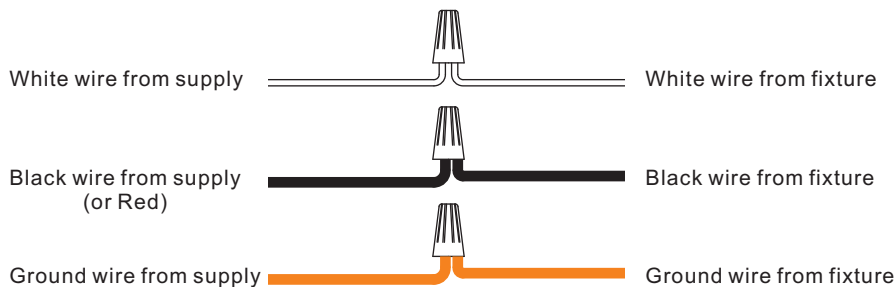

Figure 5

STEP 5– Attach Fixture Body to Post

- Coat the top 1" of the Post with Clear Silicone Caulk (not supplied) and position the Post Fitter onto the Post. Be sure to seat it completely, aligning the holes in the Fitter with the 1/16" Pilot Holes drilled into the Post.
- Secure the Fixture to Post with (3) Mounting Screws (A).

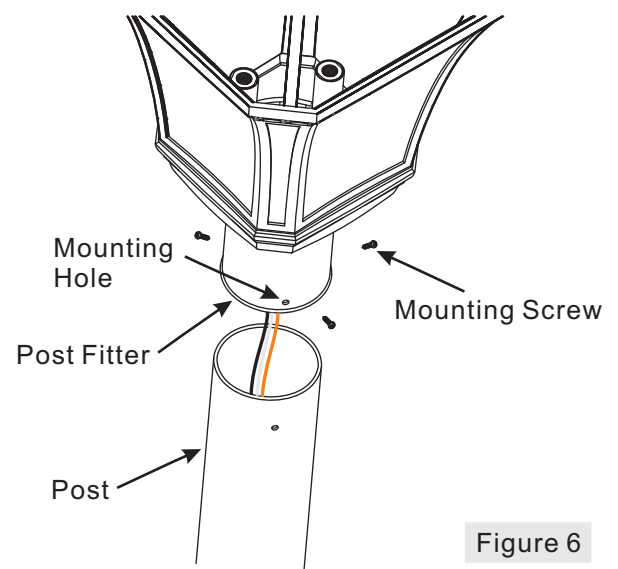

Figure 6

Thank you for purchasing a Quozel product.
Need assistance with parts or assembly? Call Quozel customer service at 1-631-273-2700
or visit us on-line at www. quozel. com

STEP 6 – Install Bulb

- A. This fixture uses standard bulb with a candelabra screw base. Maximum 60 watts.
- B. Insert bulb and screw snugly into place.

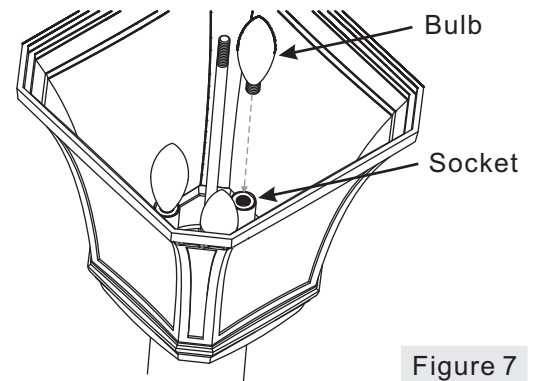
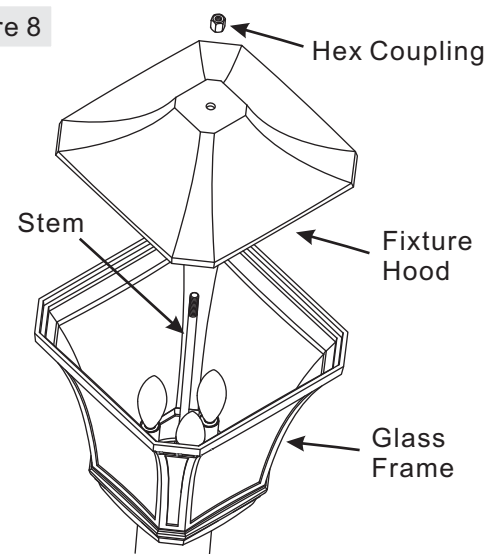

Figure 7

STEP 7 – Assemble Fixture Hood to Glass Frame

- A. Pass the Fixture Hood over the top end of the Stem, attach to the top edge of the Glass Frame. Secure by threading the Hex Coupling onto the Stem. Tighten until snug.

Figure 8



STEP 8 – Assemble Finial to Fixture Body

- A. Remove the Nipple, Strut Member, Waterproof Washer from the Finial. Screw one end of the Nipple into the Hex Coupling on the top center of the Fixture Body. Pass Strut Member and Waterproof Washer over the Nipple. Secure by threading the Finial onto the Nipple. Hand tighten until snug.

Your lamp post fixture is now assembled and ready to use. Enjoy!

Figure 9

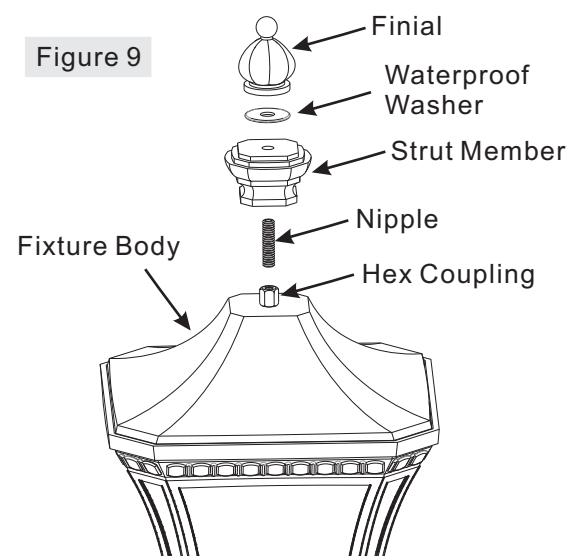

Thank you for purchasing a Quoizel product.

Need assistance with parts or assembly? Call Quoizel customer service at 1-631-273-2700
or visit us on-line at www. quozel. com