

# **Kräus<sup>®</sup>**

INSTALLATION MANUAL

## **Indy<sup>™</sup> Hands-Free Bath Faucet with Sensor**

**KSB-10001**

## **Congratulations on the purchase of your new Kraus® plumbing fixture!**

Please keep the box and packaging materials until your product is completely installed. If you have any questions, require technical assistance or have any problems with your product:



**DO NOT RETURN TO STORE**

**Please contact our Customer Service Team  
1-800-775-0703 / [customerservice@kraususa.com](mailto:customerservice@kraususa.com)**

Have the model number available and retain a copy of your receipt with purchase date for reference.

If for any reason this product does not meet your expectations, please be sure to repack this product in the original box and packaging material to avoid damage during transit.



### Prior to Installation:

- Make sure you have all necessary parts by checking the diagram and parts list. If any part is missing or damaged, please contact Kraus<sup>®</sup> Customer Service at 800-775-0703 for a replacement.
- Read all instructions and safety warnings and ensure you have all tools, parts, and equipment necessary for a safe installation.
- Turn off the hot and cold water supply at the angle stops and turn on the old faucet to release any built up pressure. Remove existing faucet.
- Pre-drilled hole size requirement: 1 3/8" (min)
- Max countertop thickness: 2 7/8"

For technical assistance or replacement parts, please contact Kraus Customer Service and one of our representatives will be happy to help:  
Toll-Free: 800-775-0703 or [Customerservice@kraususa.com](mailto:Customerservice@kraususa.com)

### Tools Required



### Care & Maintenance

\* To keep the product clean & shining, follow the steps below:

1. Rinse with clean water & dry with a soft cloth
2. Do not clean with soaps, acid, polish, abrasives or harsh cleaners
3. Do not use cloth with a coarse surface
4. Unscrew the aerator and clean when necessary

\* This installation manual is subject to change without further notice.



## Diagram and Parts List

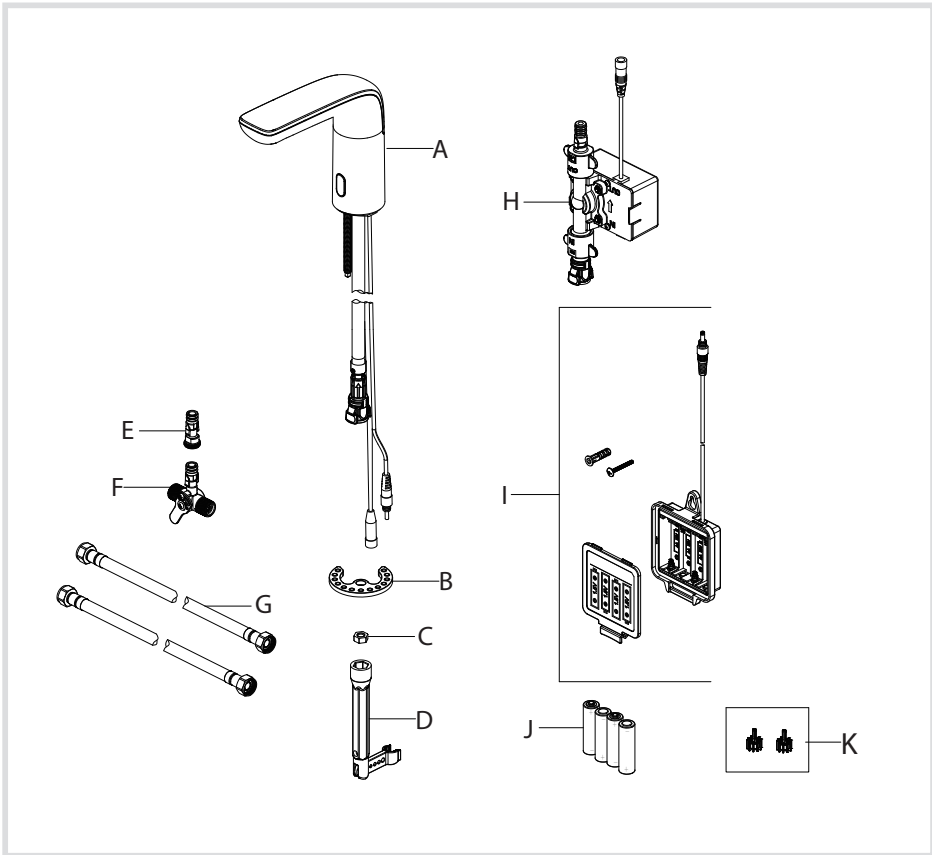

A. Faucet Body  
 B. Washer  
 C. Nut  
 D. Spanner Key  
 E. Quick Connector

F. Mixing Valve  
 G. Hose  
 H. Sensor Control Box  
 I. Battery Pack  
 J. "AA" Battery  
 K. Filter Washer

## Faucet Dimensions

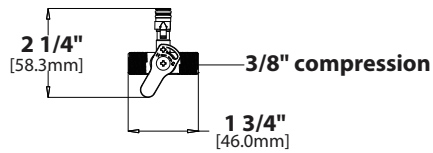
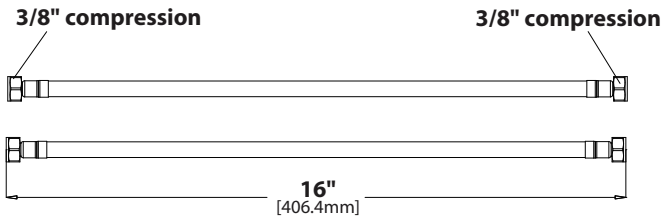
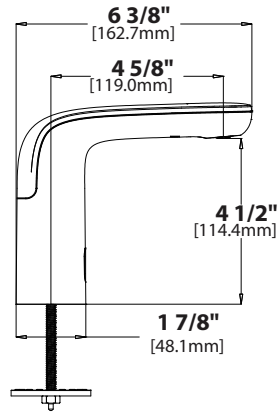
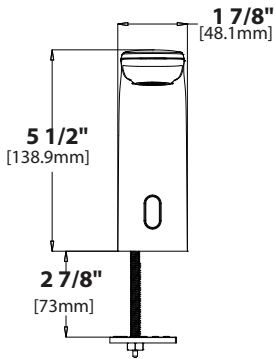

### Installer Tip:

Shut off main water supply before installing new faucet.

## Step 1: Remove washer and nut

---

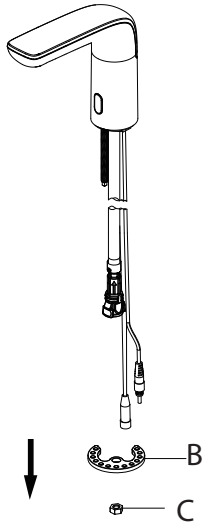

Shut off the water supply. Remove the old faucet. Before installation, remove the washer (B) and the nut (C) from the faucet by unscrewing the nut (C) in a counterclockwise direction.

## Step 2: Installing the faucet

---

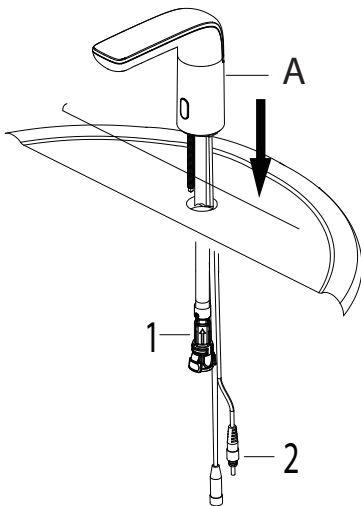

Install the faucet body (A), supply hoses (1) and sensor cable (2) through the hole in the sink or countertop.

### Step 3: Securing the faucet assembly

3.1. Install the washer (B) onto the threaded bolt.

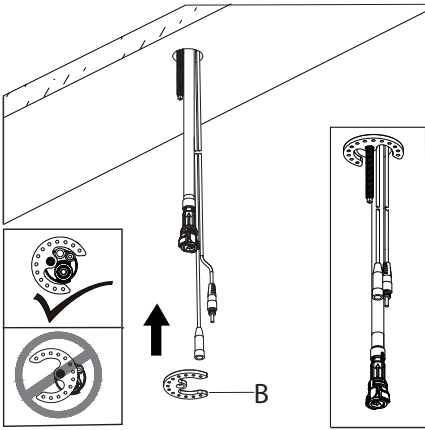

3.2. Thread the lock nut (C) onto the bolt using the spanner key (D) provided to tighten firmly. Do not overtighten.

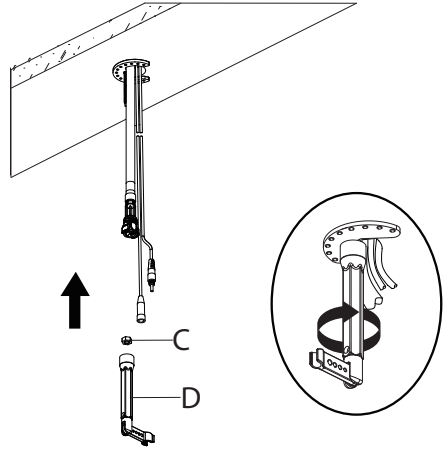

### Step 4: Installing the sensor control box

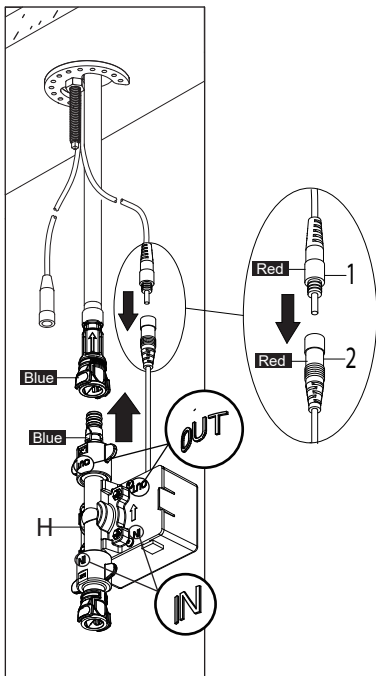

Install the sensor cable (1) to the control box connection (2). Ensure they are tightly connected by firmly pushing together. Connect the hose with the blue tag to the hose on the sensor control box (H) with a matching blue tag. Push firmly together until they snap into place.

**CAUTION:** If the connections are not made properly, the sensor feature will not work.

## Step 5: Hose installation - Hot and Cold water

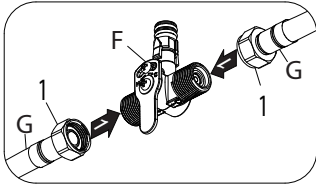

Hot and cold water adjustable mode (optional): Thread the nuts (1) on the inlet hose (G) onto the mixing valve (F) and tighten with a wrench. Do not overtighten. Connect the mixing valve (F) with the red tag to the quick connector on the sensor control box (H) with a matching red tag. Push firmly together until they snap into place.

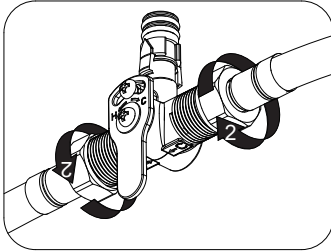

**NOTE:** This step is for hose installation using dual hot and cold water mode. If using the single cold water mode, begin with step 6.

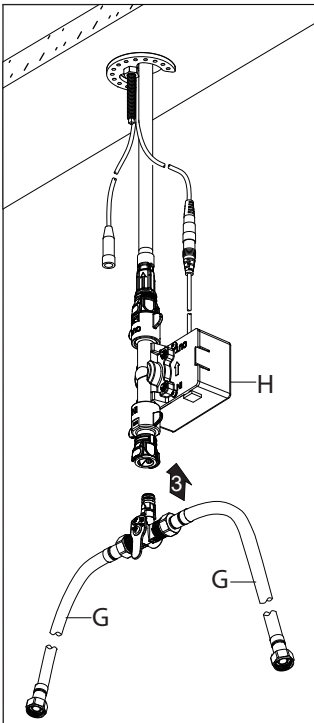



## Step 6: Hose installation - Cold water only

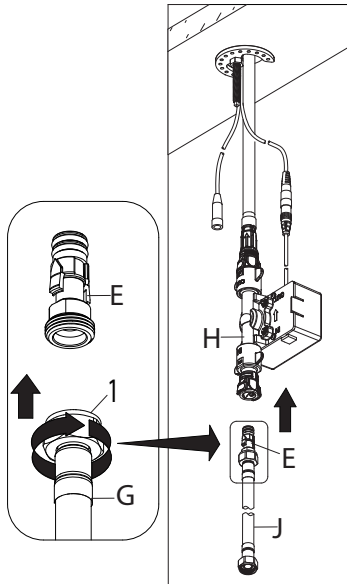

Single cold water mode (optional): Thread the nut (1) on the hose (G) onto the quick connector (E) and tighten with a wrench. Do not overtighten.

Connect the quick connector (E) with the red tag to the hose on the sensor control box (H) with a matching red tab. Push firmly together until they snap into place.

**NOTE:** This step is for hose installation using single cold water mode. If using dual hot and cold water mode, install as instructed in step 5.

## Step 7: Installing the battery pack

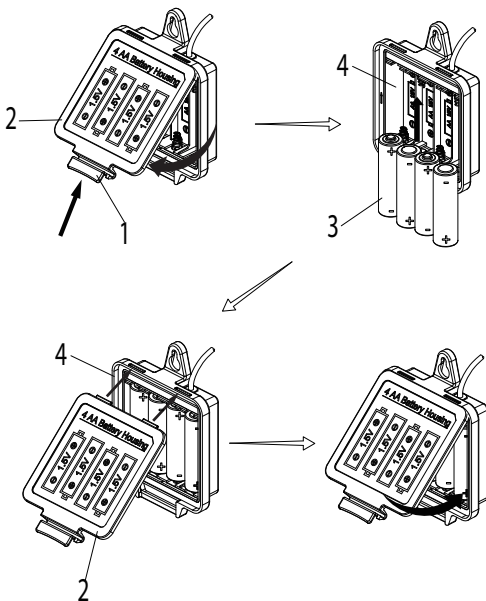

To open the battery housing, squeeze the tabs (1) on the cover (2), then remove the cover (2). Install the four AA batteries (3) included by matching the positive (+) and negative (-) ends on the battery (3) to the (+) and (-) markings in the battery pack (4). The negative ends of the battery (3) should always connect to the spring end of the battery slots in the battery pack (4). Reinstall the battery pack cover (2) by pushing up and snapping into place.

**NOTE:** When the sensor flashes 10 times continuously and slowly, the batteries have lost their charge. Replace the batteries (3).

## Step 7: Installing the battery pack - continued

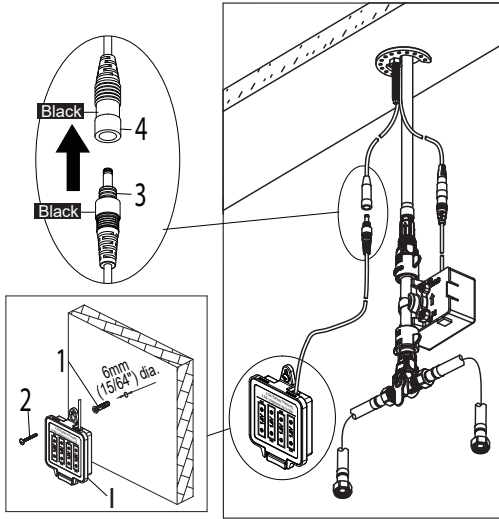

Drill a hole in the wall using a 6 mm (15/64 in.) diameter drill bit. Install the battery pack (1) using the molly anchor (1) and screw (2) provided. Insert the battery pack cable (3) into the control box connection (4).

**NOTE:** After installing the battery pack, the light on the sensor will flash and the faucet control box will make a "click" sound when you move your hand in the sensor area. If not, check to ensure the batteries are installed correctly.

## Step 8: Connect waterlines to main valve - Hot and Cold water

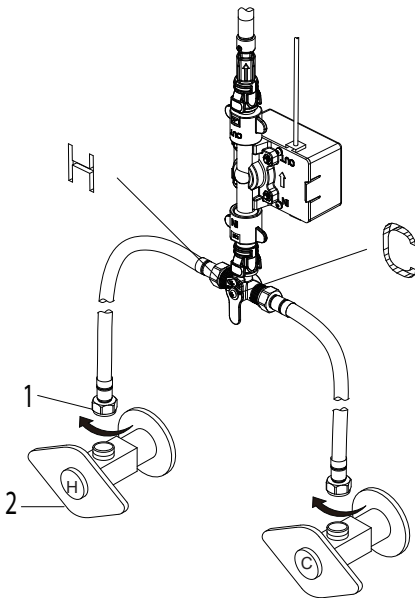

Thread the nut (1) on the supply line onto the outlet of the water supply valve (2) and tighten with a wrench. Do not overtighten. Perform this step on the hot and cold sides.

**NOTE:** This step is for the water supply connections using dual hot and cold water mode. If using the single cold water mode, install as instructed in step 9.

## Step 9: Connect waterlines to main valve - Cold water only

---

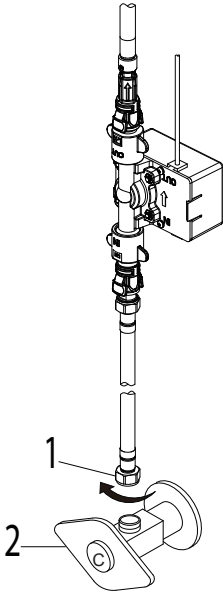

Thread the nut (1) on the supply line onto the outlet of the water supply valve (2) and tighten with a wrench. Do not overtighten. Only perform this step on the cold water side.

**NOTE:** This step is for the water supply connections using single cold water mode. If using dual hot and cold water mode, install as instructed in step 8.

## Step 10: Flushing and checking for leaks

---

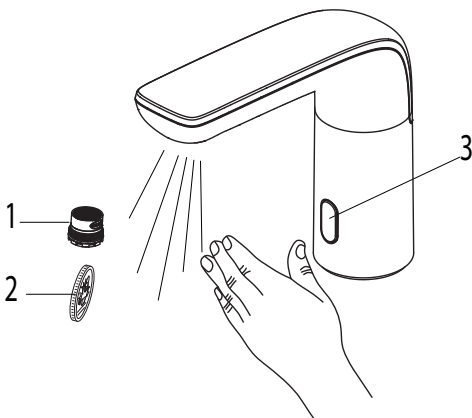

Important: After the installation is complete, remove the aerator (1) with a coin (2) to flush the water lines. Turn on the water supply to check for leaks. If you discover any leaks, check your connections to ensure they are installed properly. Turn the water on by activating the sensor (3) by keeping your hand within 4 3/4 inches of the sensor and allow both hot and cold water to run for at least one minute each. This flushes away any debris that could cause damage to internal parts. Turn off the water and reinstall the aerator.

## Step 11: Operating the sensor

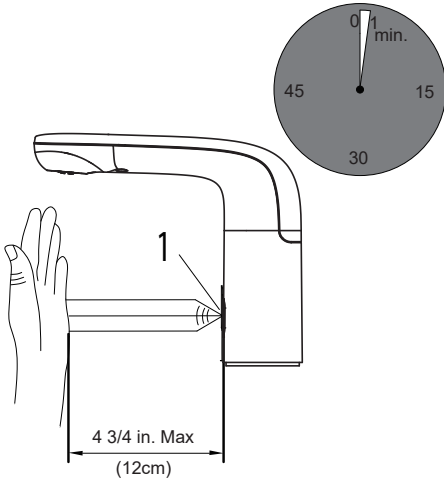

Turn the water on by activating the sensor (1) by keeping your hand within 4 inches of the sensor. When removing your hand from within 4 3/4 inches of the sensor, the water will turn off.

The initial water outlet temperature is the coldest state. Adjust the temperature by rotating the adjustment plate (2). Rotating the plate (2) to the right will make the water hotter.

If you are having trouble with the sensor, please refer to the troubleshooting section.

**NOTE:** As a water saving feature, the water will turn off automatically after 1 minute of continuous flow.

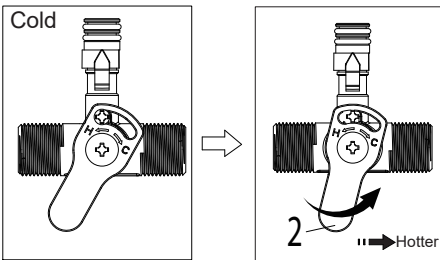

# Replacement Parts

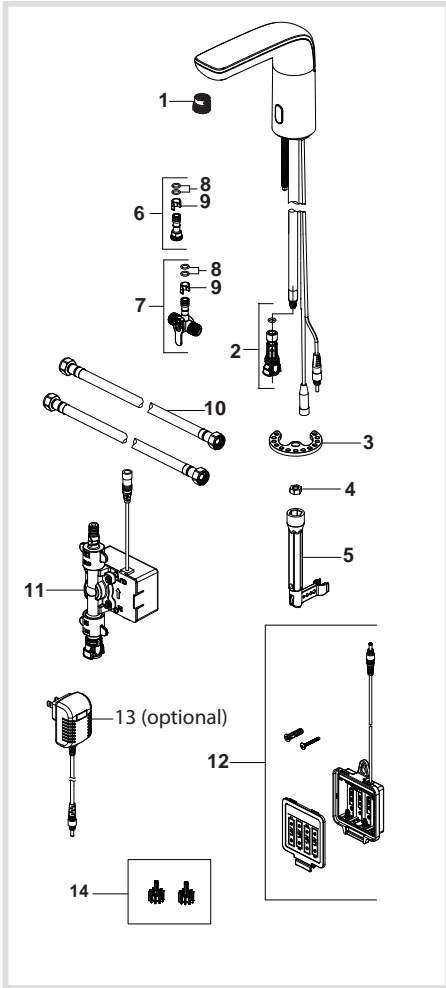

Replacement Parts List	Finish / Color	Part #
1. Aerator		KP27163
2.Quick connector assembly		KP27328
3. Metal washer		KP27198
4. Nut		KP27327
5. Spanner Key		KP27329
6.Connector assembly		KP27330
7. Mixing Valve		KP27331
8.O-Ring		KP27092
9. Block		KP27073
10. Hot and Cold waterlines		KP27333
11. Control Box		KP27332
12. Battery Housing		KP27188
13. AC Adapter (optional)		KP27187
14. Filter Washer		KP27334

# Troubleshooting

If you have followed the instructions carefully and your faucet still does not work properly, take the following corrective steps:

## Problem 1: The light on the sensor is flashing continuously.

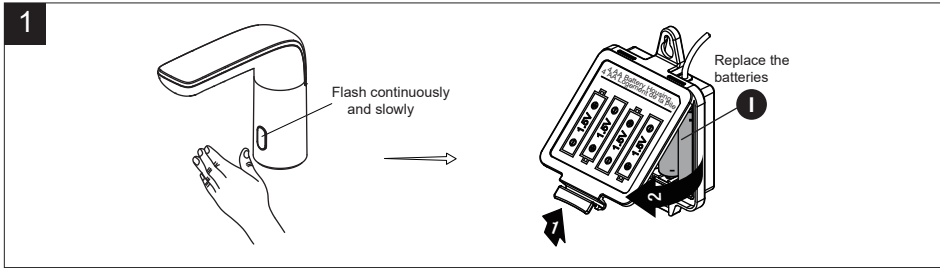

Turn on the water supply and move your hand in the sensor area. If the sensor flashes continuously and slowly, then replace the 4 "AA" batteries.

## Problem 2: The sensor is not activating the water flow.



When you move your hand within 4 3/4 inches of the sensor, the water does not turn on as it should.

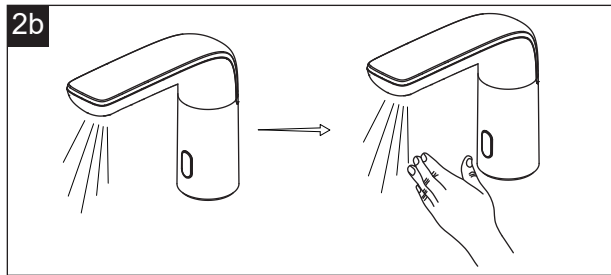

Or, when you move your hand further than 4 3/4 inches from the sensor, the water does not turn off as it should.

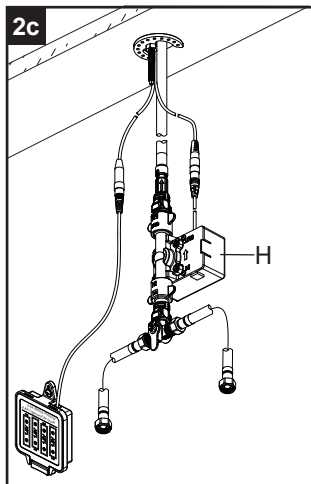

This indicates that the control box (H) is damaged. Call customer service to request a replacement control box. Replace the old control box with the new control box.

**Problem 3: There is a low flow of water.**



There is a low flow of water or LED indicator in the faucet is not functioning.

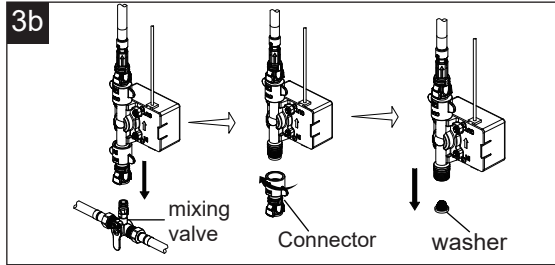

This could indicate that the washer in the "in" end of the control box is dirty or damaged. Remove the mixing valve and unscrew the connector. Take out the washer from the control box. Clean the washer or replace the washer. Reassemble the connector and mixing valve.

## Codes/Standards Applicable:



NSF/ANSI 61



ASME A112.18.1  
1.2GPM 4.5L/min maximum

### Faucet - Lifetime Limited Warranty

Kraus® USA Plumbing, LLC ("Kraus") extends this warranty to the original purchaser for personal household use of the Faucet when purchased from an authorized Kraus dealer and in the location of original installation. This warranty is non-transferable.

Kraus warrants the structure and finish of the Faucet to be free from defects in material and workmanship under normal usage for as long as the original purchaser resides in the residence in which the Faucet was first installed.

Kraus warrants the Faucet's sprayhead assembly (including the engine, aerators, structure, restrictors, back flow preventers, sprayer hoses, braided supply line hoses which encompasses nylon, silicon and stainless steel) of the product to be free from defects in material and workmanship under normal usage for a period of one (1) year from the date of purchase.

Kraus warrants the Faucet's cartridge to be free from defects in material and workmanship under normal usage for a period of five (5) years from the date of purchase.

Any product reported to the authorized dealer or to Kraus as being defective within the warranty period will be repaired or replaced with a product of equal value at the option of Kraus.

### Commercial Warranty

Kraus USA Plumbing, LLC ("Kraus") warrants its Products for a period of one (1) year to commercial purchasers of Products used in industrial, commercial and business applications.

### Care and Cleaning Instructions

Certain cleaning products may cause damage to a Product's finish and use of the following on the Product will void this warranty:

- Abrasive cleaners such as powders, bleach, ammonia, alcohol or chlorine
- Abrasive pads, steel wool or wire brushes

### What is Not Covered

This warranty does not cover Products that were discontinued when purchased or display Products, whether such Products were purchased at discount outlets, unauthorized dealers, and/or sold on clearance. This warranty does not cover any free gifts included with purchase.

This warranty does not cover damage resulting from neglect, misuse (including use for an unintended application), abuse, carelessness, accident, hard water or mineral deposits, exposure to corrosive materials, improper maintenance, alteration of the Product, or failure to follow care, cleaning or installation instructions enclosed with your Product. Kraus recommends that all Kraus Products be installed by a fully licensed and insured trade professional with experience in the installation of bathroom and/or kitchen manufactured goods.



#### How to Make a Warranty Claim

If you are a **consumer purchaser**, please contact a Kraus® Customer Service Representative at:  
Kraus USA Plumbing, LLC  
12 Harbor Park Drive  
Port Washington, NY 11050  
Toll-free 800-775-0703  
Customerservice@kraususa.com

If you are a **plumbing contractor or trade professional**, please contact a Kraus Pro Representative at:  
Kraus USA Plumbing, LLC  
12 Harbor Park Drive  
Port Washington, NY 11050  
516-801-8955  
Proservice@kraususa.com

If you are an **authorized partner**, please contact a Partner Support Representative at:  
Kraus USA Plumbing, LLC  
12 Harbor Park Drive  
Port Washington, NY 11050  
516-801-8954  
Partnersupport@kraususa.com

In requesting warranty service, please be ready to provide your proof of purchase and a description of the problem. Shipping charges will be covered for the first (1) year of the warranted replacement part or product (HI, AK, and Puerto Rico shipping charges may apply). International shipping fees are not included.

#### Limitation on Duration of Implied Warranties

Please note that some states/provinces (including Quebec) do not allow limitations on how long an implied warranty lasts, so the below limitations may not apply to you. TO THE MAXIMUM EXTENT PERMITTED BY APPLICABLE LAW, ANY IMPLIED WARRANTY, INCLUDING THE IMPLIED WARRANTIES OF MERCHANTABILITY AND OF FITNESS FOR A PARTICULAR PURPOSE, IS LIMITED TO THE STATUTORY PERIOD OR THE DURATION OF THIS WARRANTY, WHICHEVER IS SHORTER.

#### Limitation of Special, Incidental or Consequential Damages

Please note that some states/provinces (including Quebec) do not allow the exclusion or limitation of special, incidental or consequential damages, so the below limitations and exclusions may not apply to you. TO THE MAXIMUM EXTENT PERMITTED BY APPLICABLE LAW, THIS WARRANTY DOES NOT COVER, AND KRAUS USA PLUMBING, LLC SHALL NOT BE LIABLE FOR, ANY SPECIAL, INCIDENTAL OR CONSEQUENTIAL DAMAGES (INCLUDING LABOR CHARGES TO REPAIR, REPLACE, INSTALL OR REMOVE THIS PRODUCT), WHETHER ARISING OUT OF BREACH OF ANY EXPRESS OR IMPLIED WARRANTY, BREACH OF CONTRACT, TORT, OR OTHERWISE.

This warranty gives you specific legal rights, and you may also have other rights which vary from state/province to state/province.

**Download the Kraus Care & Maintenance Guide at:**  
<http://www.kraususa.com/maintenance>

# IMPORTANT

## Register Your Kraus Product

**Activate** Your Warranty

**Access** Premium Customer Support

**Get** Product Information

**REGISTER TODAY**

<http://www.kraususa.com/registration>



**Kräus**<sup>®</sup>  
www.kraususa.com