

CUSTOMER REFERENCE DRAWING

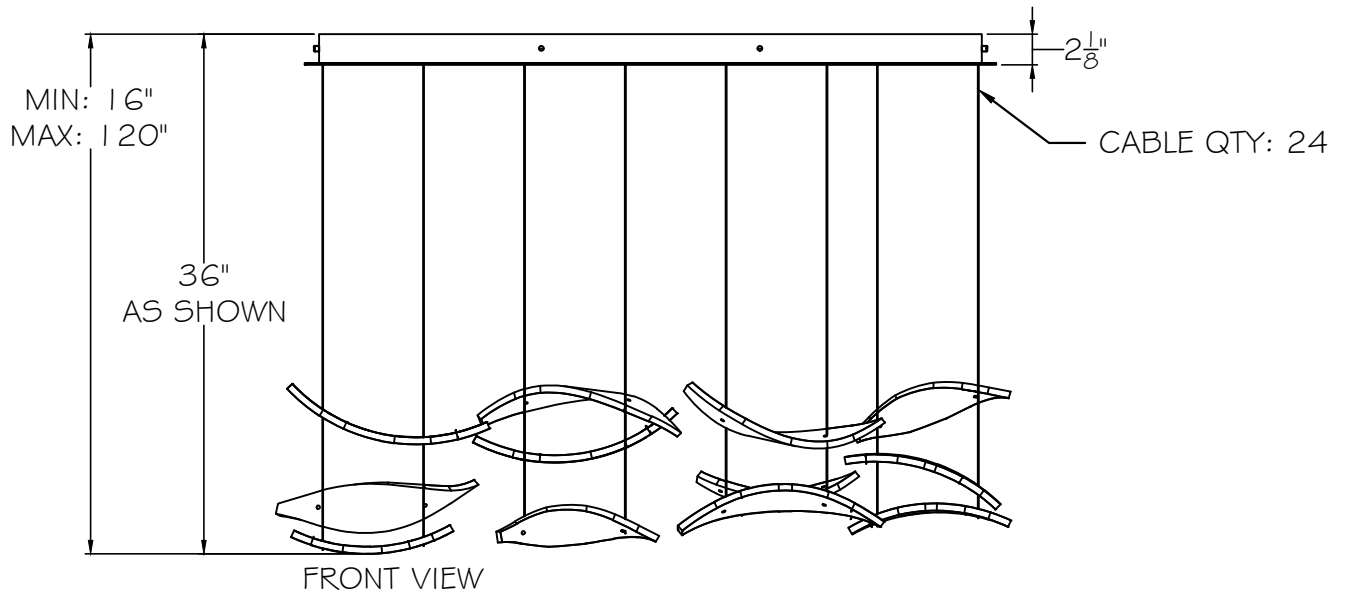

THUMBNAIL IMAGES OF STYLE OPTIONS:

-111 SILVER
-211 GOLD

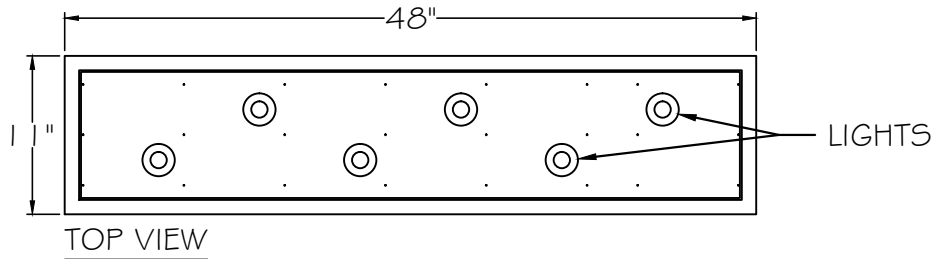

GLASS PLUME WITH DICHRO (X12)

-121 SILVER
-221 GOLD



GLASS PLUME NO DICHRO (X12)

-131 SILVER
-231 GOLD



GLASS SPIRE CLEAR (X18)

-141 SILVER
-241 GOLD



GLASS SPIRE BLACK (X18)



This drawing, specifications and the product depicted are the exclusive property of Fine Art Handcrafted Lighting®. In compliance with US copyright and patent requirements, notice is hereby given that this document and the product depicted shall not be copied, altered or used in any manner without the expressed written consent of Fine Art Handcrafted Lighting®.

www.finearthl.com

Tel:(305) 821-3850
FINE ART LAMPS®

Fax:(305) 513-5736

STYLE NUMBER:

895140

DATE:

4/17/2020

INSTRUCTION

NOTE: ORIENTATION OF CANOPY IS CRITICAL TO GLASS DROP DESIGN

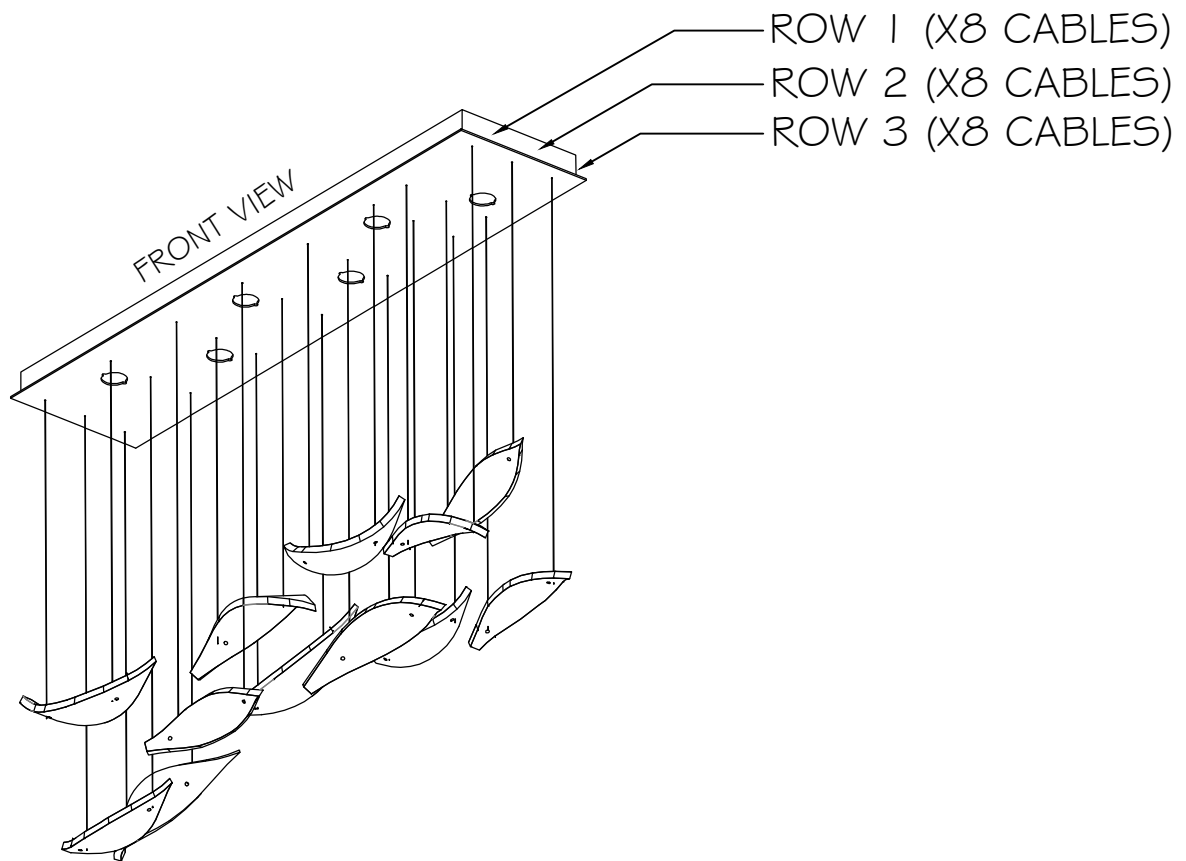

STYLE(S) #: 895140-111 -211 -121 -221

**FINE
ART
LAMPS®**
EST. 1940

This drawing, specifications and the product depicted are the exclusive property of FINE ART LAMPS®. In compliance with US copyright and patent requirements, notice is hereby given that this document and the product depicted shall not be copied, altered or used in any manner without the expressed written consent of FINE ART LAMPS®.
www.fineartlamps.com

Tel:(305) 821-3850 Fax:(305) 821-1564

INSTRUCTION #:

00791410

SHEET

1 / 5

GLASS INSTALLATION INSTRUCTION

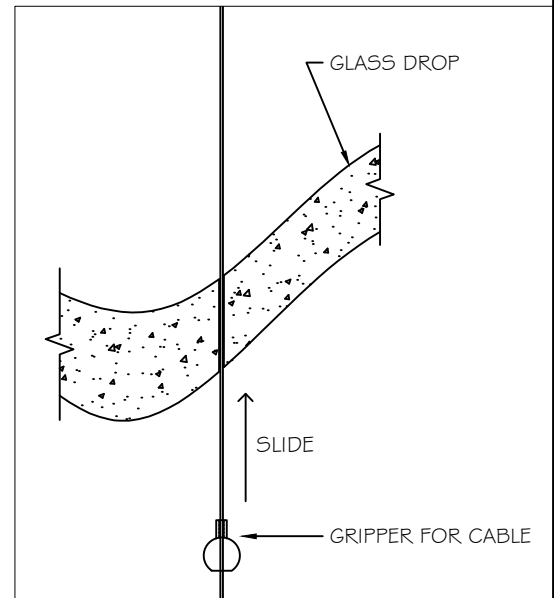
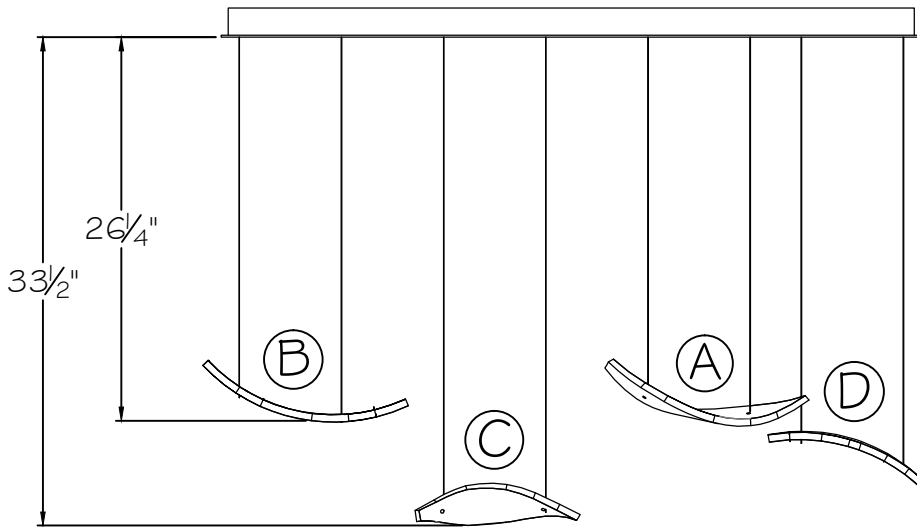
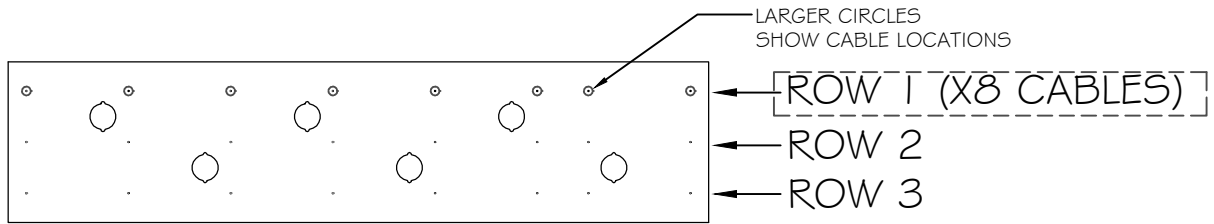

ROW 1

GLASS TYPE	QUANTITY
TYPE A	1
TYPE B	1
TYPE C	1
TYPE D	1

- FIRST ROW OF GLASSES TO BE INSTALLED IS ROW 1.
- GATHER ALL OTHER CABLES TO THE SIDE TO EASILY ACCESS LAYER TO BE WORKED ON
- LETTERS IN CIRCLES ON DIAGRAM INDICATE GLASS TYPE THAT CORRESPONDS TO STICKERS ON GLASS
- START SLIDING GLASSES UP INTO POSITION AS SHOWN ON FRONT VIEW, STARTING FROM TOP TO BOTTOM
- SLIDE GRIPPER UP TO HOLD POSITION OF GLASS
- NOTE: MULTIPLE GLASSES MAY USE THE SAME CABLES

STYLE(S) #: 895140-111 -211 -121 -221

**FINE
ART
LAMPS®**
EST. 1940

This drawing, specifications and the product depicted are the exclusive property of FINE ART LAMPS®. In compliance with US copyright and patent requirements, notice is hereby given that this document and the product depicted shall not be copied, altered or used in any manner without the expressed written consent of FINE ART LAMPS®.

www.fineartlamps.com
Tel:(305) 821-3850 Fax:(305) 821-1564

INSTRUCTION #:

00791410

SHEET

2 / 5

GLASS INSTALLATION INSTRUCTION

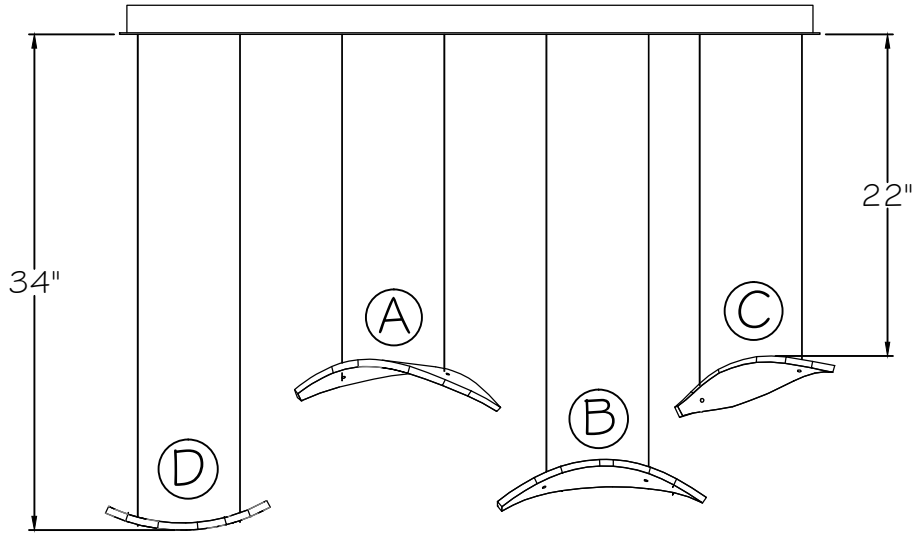
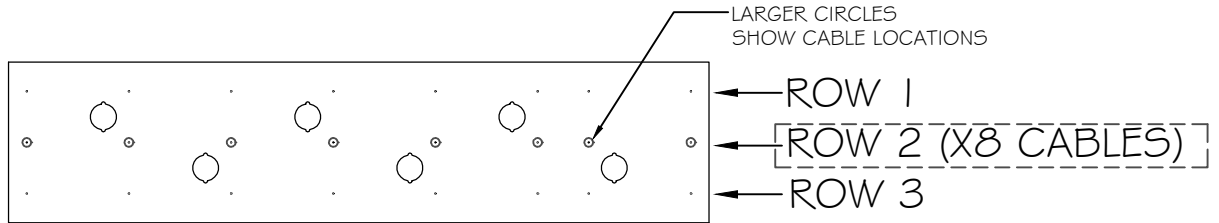

ROW 2

GLASS TYPE	QUANTITY
TYPE A	1
TYPE B	1
TYPE C	1
TYPE D	1

- NEXT ROW OF GLASSES TO BE INSTALLED IS ROW 2.
- START SLIDING GLASSES UP INTO POSITION AS SHOWN ON FRONT VIEW, STARTING FROM TOP TO BOTTOM
- SLIDE GRIPPER UP TO HOLD POSITION OF GLASS
- NOTE: MULTIPLE GLASSES MAY USE THE SAME CABLES

STYLE(S) #: 895140-111 -211 -121 -221

**FINE
ART
LAMPS®**
EST. 1940

This drawing, specifications and the product depicted are the exclusive property of FINE ART LAMPS®. In compliance with US copyright and patent requirements, notice is hereby given that this document and the product depicted shall not be copied, altered or used in any manner without the expressed written consent of FINE ART LAMPS®.

www.fineartlamps.com
Tel:(305) 821-3850 Fax:(305) 821-1564

INSTRUCTION #:

00791410

SHEET

3 / 5

GLASS INSTALLATION INSTRUCTION

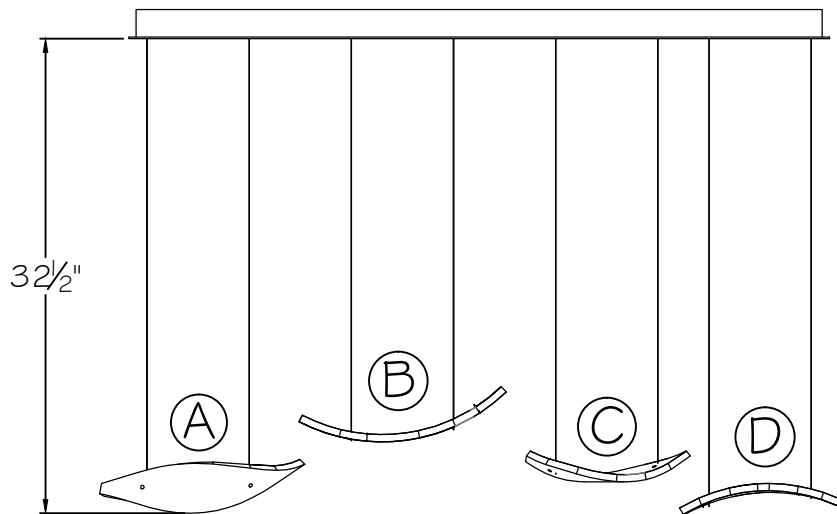
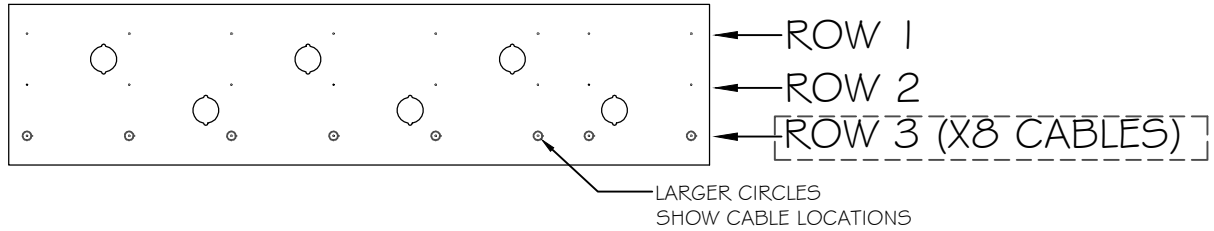

ROW 3	
GLASS TYPE	QUANTITY
TYPE A	1
TYPE B	1
TYPE C	1
TYPE D	1

- NEXT ROW OF GLASSES TO BE INSTALLED IS ROW 3.
- START SLIDING GLASSES UP INTO POSITION AS SHOWN ON FRONT VIEW, STARTING FROM TOP TO BOTTOM
- SLIDE GRIPPER UP TO HOLD POSITION OF GLASS
- NOTE: MULTIPLE GLASSES MAY USE THE SAME CABLES

STYLE(S) #: 895140-111 -211 -121 -221

**FINE
ART
LAMPS®**
EST. 1940

This drawing, specifications and the product depicted are the exclusive property of FINE ART LAMPS®. In compliance with US copyright and patent requirements, notice is hereby given that this document and the product depicted shall not be copied, altered or used in any manner without the expressed written consent of FINE ART LAMPS®.

www.fineartlamps.com

Tel:(305) 821-3850 Fax:(305) 821-1564

INSTRUCTION #:

00791410

SHEET

4 / 5

GLASS INSTALLATION INSTRUCTION

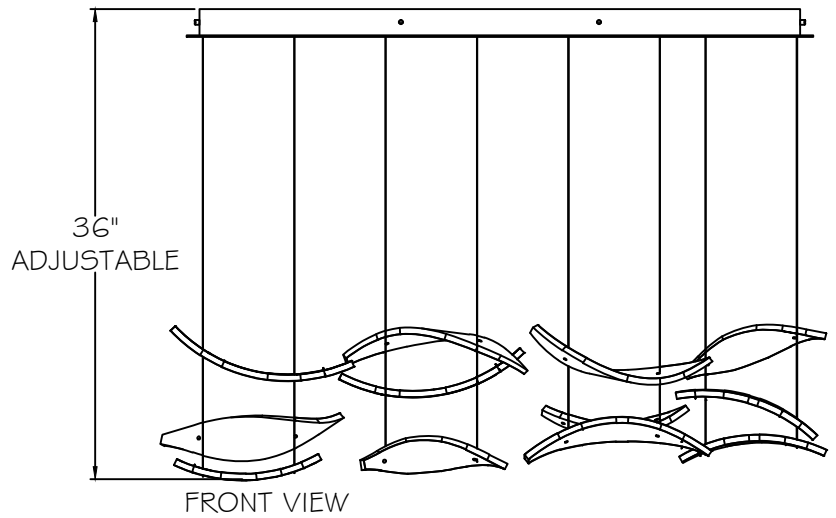
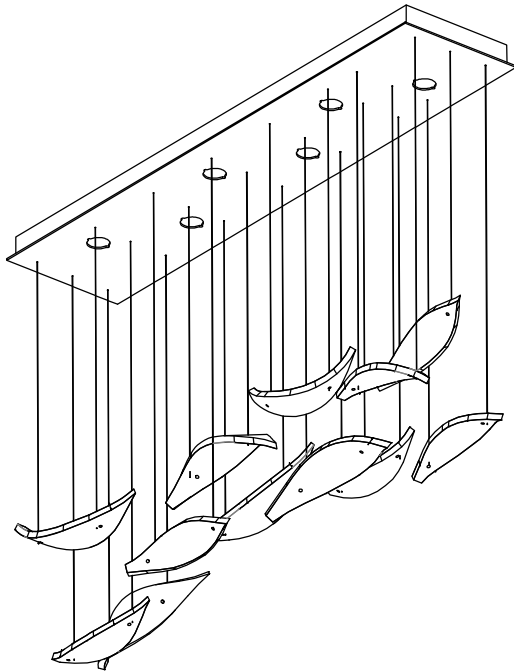

- ONCE ALL GLASSES ARE INSTALLED AND FINAL GLASS POSITION IS ACHIEVED, ENSURE TO CUT EXCESS CABLES UP TO HARDWARE OF LOWEST GLASSES

STYLE(S) #: 895140-111 -211 -121 -221

**FINE
ART
LAMPS®**
EST. 1940

This drawing, specifications and the product depicted are the exclusive property of FINE ART LAMPS®. In compliance with US copyright and patent requirements, notice is hereby given that this document and the product depicted shall not be copied, altered or used in any manner without the expressed written consent of FINE ART LAMPS®.
www.fineartlamps.com

Tel:(305) 821-3850 Fax:(305) 821-1564

INSTRUCTION #:

00791410

SHEET

5 / 5

INSTRUCTION

NOTE:ORIENTATION OF CANOPY IS CRITICAL TO GLASS DROP DESIGN

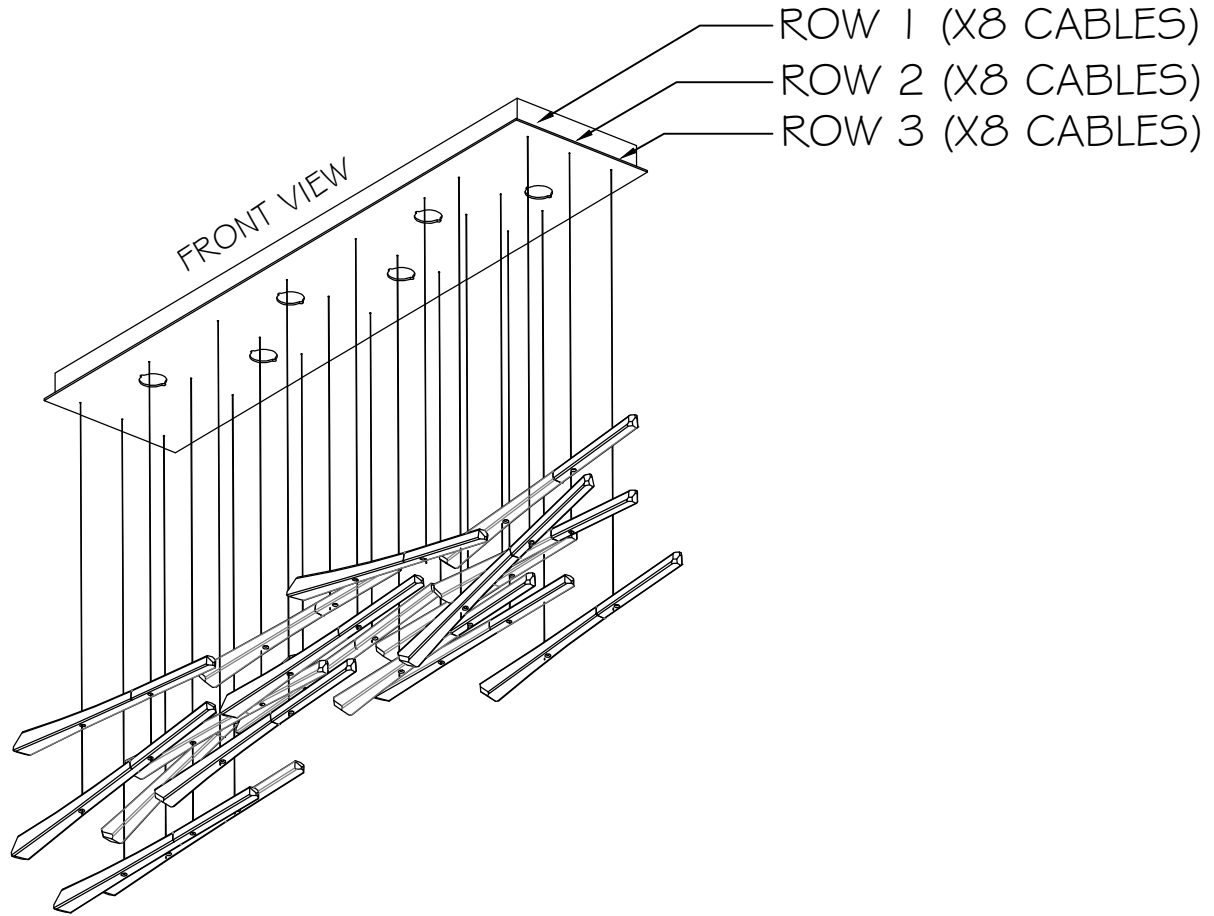

STYLE(S) #: 895140-131 -231 -141 -241

**FINE
ART
LAMPS®**
EST. 1940

This drawing, specifications and the product depicted are the exclusive property of FINE ART LAMPS®. In compliance with US copyright and patent requirements, notice is hereby given that this document and the product depicted shall not be copied, altered or used in any manner without the expressed written consent of FINE ART LAMPS®.

www.fineartlamps.com
Tel:(305) 821-3850 Fax:(305) 821-1564

INSTRUCTION #:

00791411

SHEET

1 / 5

GLASS INSTALLATION INSTRUCTION

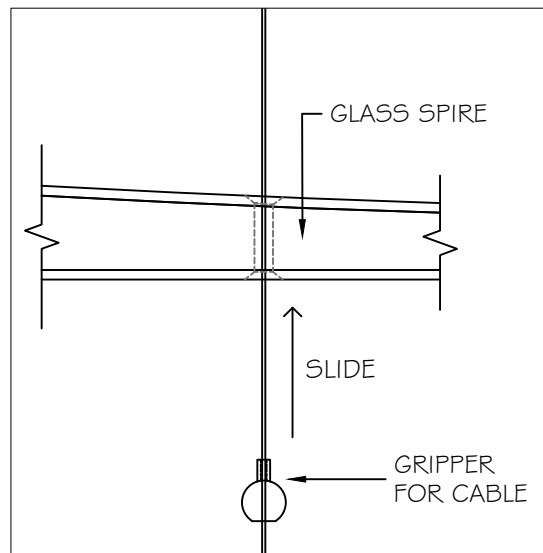
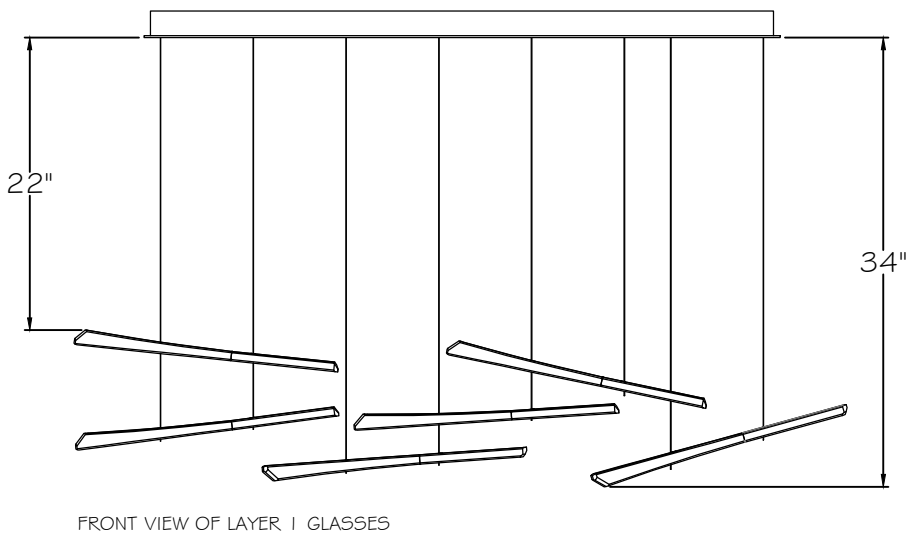
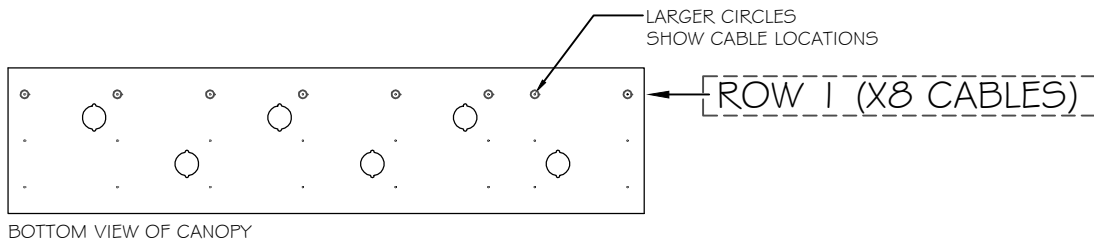

- FIRST ROW OF GLASSES TO BE INSTALLED IS ROW 1.
- GATHER ALL OTHER CABLES TO THE SIDE TO EASILY ACCESS LAYER TO BE WORKED ON
- START SLIDING GLASSES UP INTO POSITION AS SHOWN ON FRONT VIEW, STARTING FROM TOP TO BOTTOM
- SLIDE GRIPPER UP TO HOLD POSITION OF GLASS
- NOTE: MULTIPLE GLASSES MAY USE THE SAME CABLES

STYLE(S) #: 895140-131 -231 -141 -241

**FINE
ART
LAMPS®**
EST. 1940

This drawing, specifications and the product depicted are the exclusive property of FINE ART LAMPS®. In compliance with US copyright and patent requirements, notice is hereby given that this document and the product depicted shall not be copied, altered or used in any manner without the expressed written consent of FINE ART LAMPS®.

www.fineartlamps.com
Tel:(305) 821-3850 Fax:(305) 821-1564

INSTRUCTION #:

00791411

SHEET

2 / 5

GLASS INSTALLATION INSTRUCTION

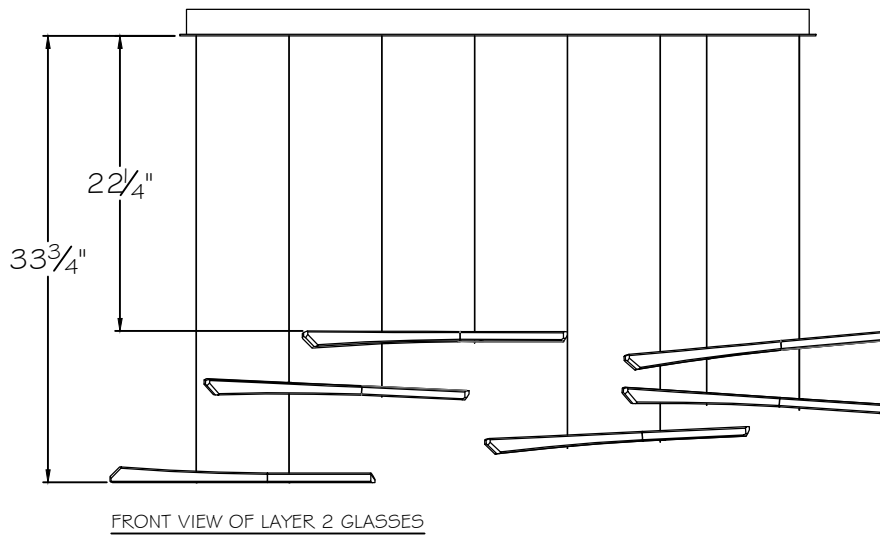
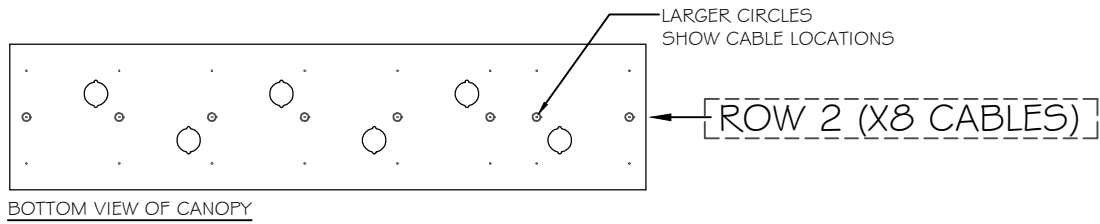

- NEXT ROW OF GLASSES TO BE INSTALLED IS ROW 2.
- START SLIDING GLASSES UP INTO POSITION AS SHOWN ON FRONT VIEW, STARTING FROM TOP TO BOTTOM
- SLIDE GRIPPER UP TO HOLD POSITION OF GLASS
- NOTE: MULTIPLE GLASSES MAY USE THE SAME CABLES

STYLE(S) #: 895140-131 -231 -141 -241

**FINE
ART
LAMPS®**
EST. 1940

This drawing, specifications and the product depicted are the exclusive property of FINE ART LAMPS®. In compliance with US copyright and patent requirements, notice is hereby given that this document and the product depicted shall not be copied, altered or used in any manner without the expressed written consent of FINE ART LAMPS®.

www.fineartlamps.com
Tel:(305) 821-3850 Fax:(305) 821-1564

INSTRUCTION #:

00791411

SHEET

3 / 5

GLASS INSTALLATION INSTRUCTION

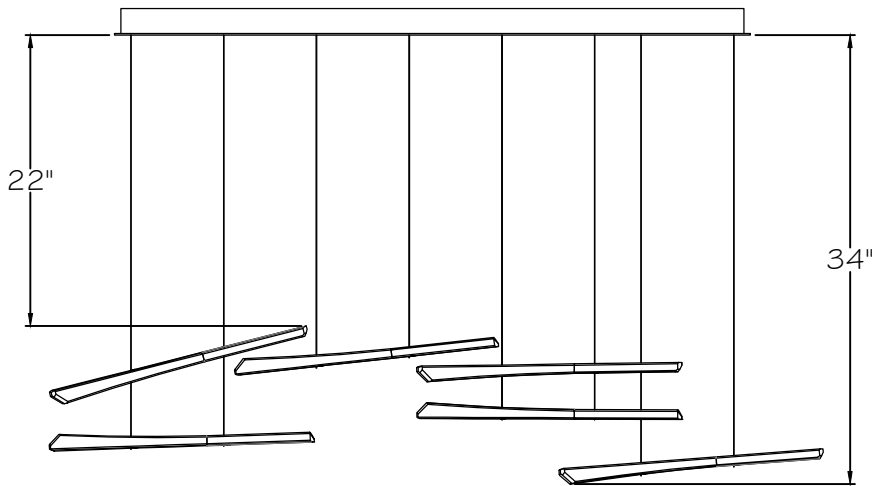
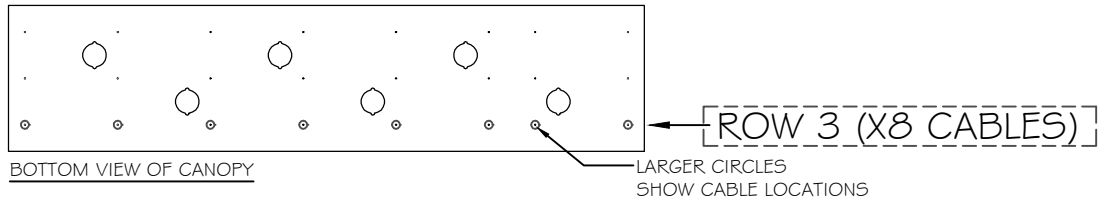

FRONT VIEW OF LAYER 3 GLASSES

- NEXT ROW OF GLASSES TO BE INSTALLED IS ROW 3.
- START SLIDING GLASSES UP INTO POSITION AS SHOWN ON FRONT VIEW, STARTING FROM TOP TO BOTTOM
- SLIDE GRIPPER UP TO HOLD POSITION OF GLASS
- NOTE: MULTIPLE GLASSES MAY USE THE SAME CABLES

STYLE(S) #: 895140-131 -231 -141 -241

**FINE
ART
LAMPS®**
EST. 1940

This drawing, specifications and the product depicted are the exclusive property of FINE ART LAMPS®. In compliance with US copyright and patent requirements, notice is hereby given that this document and the product depicted shall not be copied, altered or used in any manner without the expressed written consent of FINE ART LAMPS®.

www.fineartlamps.com
Tel:(305) 821-3850 Fax:(305) 821-1564

INSTRUCTION #:

00791411

SHEET

4 / 5

GLASS INSTALLATION INSTRUCTION

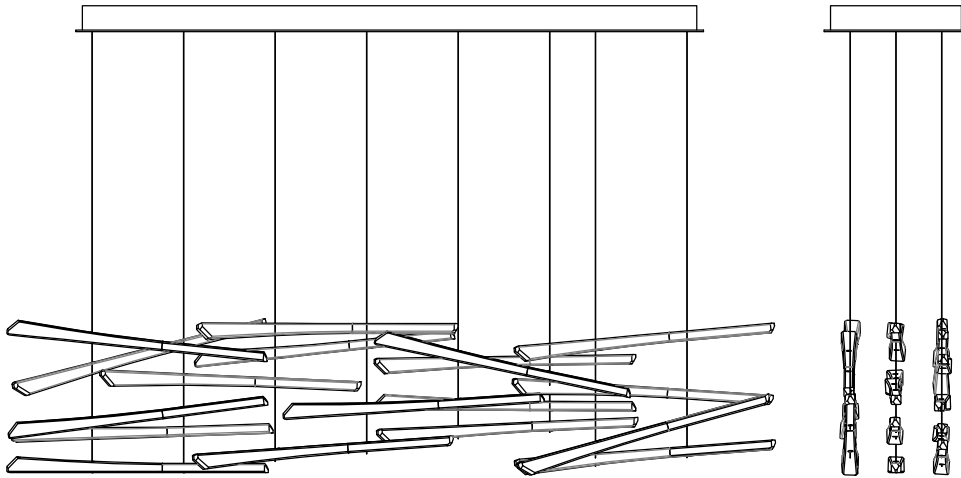

- ONCE ALL GLASSES ARE INSTALLED AND FINAL GLASS POSITION IS ACHIEVED, ENSURE TO CUT EXCESS CABLES UP TO HARDWARE OF LOWEST GLASSES. REFERENCE INSTALLATION INSTRUCTION.

STYLE(S) #: 895140-131 -231 -141 -241

**FINE
ART
LAMPS®**
EST. 1940

This drawing, specifications and the product depicted are the exclusive property of FINE ART LAMPS®. In compliance with US copyright and patent requirements, notice is hereby given that this document and the product depicted shall not be copied, altered or used in any manner without the expressed written consent of FINE ART LAMPS®.
www.fineartlamps.com

Tel:(305) 821-3850 Fax:(305) 821-1564

INSTRUCTION #:

00791411

SHEET

5 / 5