

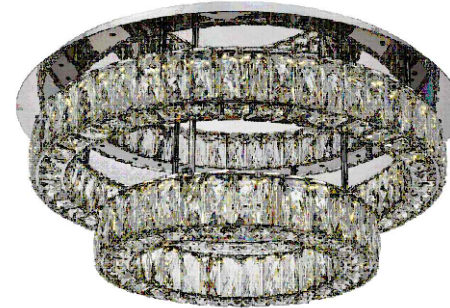

Installation manual for 3503F26L2C

Dimensions : D25.6" H10"
Collection : Monroe
Bulb Type : LED PCB 54W 4000K
Lamp Weight :32.8LBS
Total Weight :38LBS



Thank you for choosing our product(s).
Our Company is actively involved in every step of
the production.
Our product(s) are designed to be utilized for
every application that graces your home or
business.
We pride ourselves in providing the most prompt
and courtesy service to all of the valued
customers.
Please find the enclosed detailed instructions and
read carefully for proper installation. If you
have any questions, our professional customer
service team is committed to assisting you, please
call our toll free HOTLINE AT:

1-888-388-3390   US

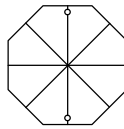

3503F26L2 D25.6" H10"

SAFETY

Warning: MAKE SURE THE ELECTRICITY TO THE WIRES YOU ARE WORKING ON IS SHUT OFF. BY EITHER REMOVING THE FUSE OR TURNING OFF THE CIRCUIT BREAKER.

CAUTION

- Before assembling the lighting fixture, please read all instructions carefully.
- All frame & crystal components are fragile, please handle with care.
- Required supply circuit : 110 - 130V/60Hz
- Labeled wires are "L" for live wire, "N" for neutral wire, "E" for ground wire.
- Never install fixture on damp ceiling, the room should be dry and well ventilated
- All electrical components must be installed by a licensed electrician and in accordance with the National Electrical Code and the appropriate local electrical codes.

Unpack the Package

Please open the box carefully and check all the items are inside the box. If you have any installation, assembling and missing parts questions, please call our Customer Service department at 1-888-388-3390. Please have model number(at the front page), where you purchase from and any other relevant information ready, our customer service team will provide comprehensive and worry free service to our valued customers.

①

3503F26L2 D25.6" H10"

Frame Assembly Diagram

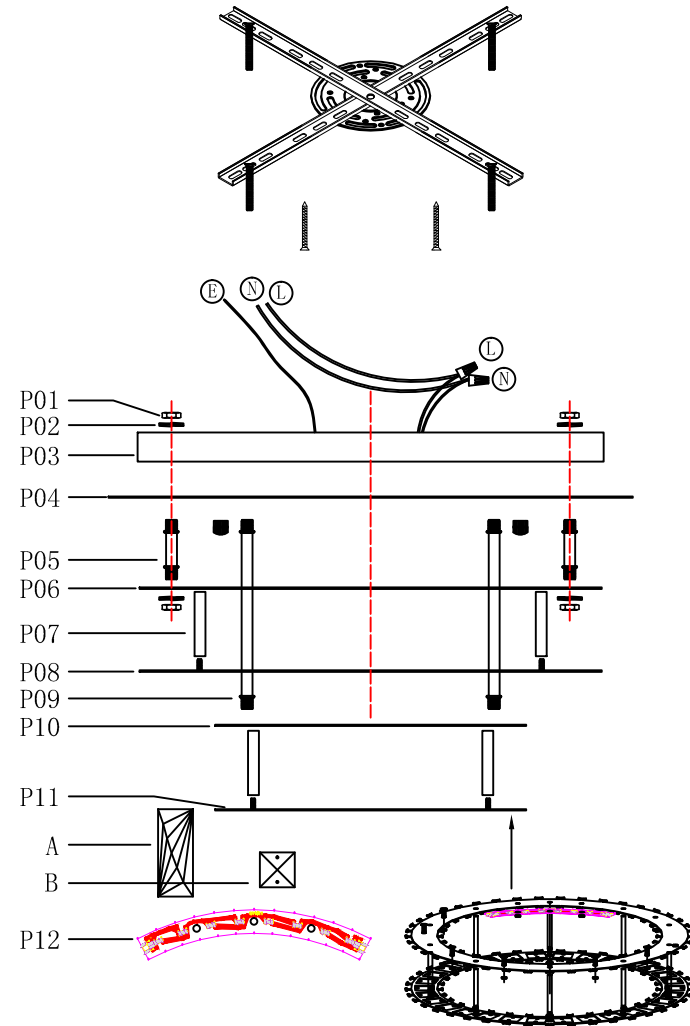

②















3503F26L2 D25.6" H10"

Step 1

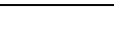
Please use the partslist to ensure you are not missing any parts.





3503F26L2

PARTS LIST

Part #	Picture	Description	Qty	Check list
ZA		crossing bracket	1	
ZB		5*50 bracket screw	4	
ZC		M4*40 screw	4	
ZD		junction cap	2	
ZE		screw cap	4	
ZF		5/32*40 screw	2	
P01		M10*T5 nut	6	
P02		screw pad	6	
P03		ø24" canopy	1	
P04		ø26" S.S plate	1	
P05		2" screw ends pipe	4	
P06		ø24" S.S plate upside	1	
P07		M5*60 metal pipe	24	
P08		ø24" S.S plate downside	1	
P09		7" screw ends pipe	3	

03

3503F26L2 D25.6" H10"

Part #	Picture	Description	Qty	Check list
P10		16" S.S ring up part	1	
P11		16" S.S ring down part	1	
P12		LED PCB 4W	12	
A		1.2*3" crystal	168	
B		1.2*1.2" crystal	72	

04

3503F26L2 D25.6" H10"

Step 2

Canopy Installation Instruction

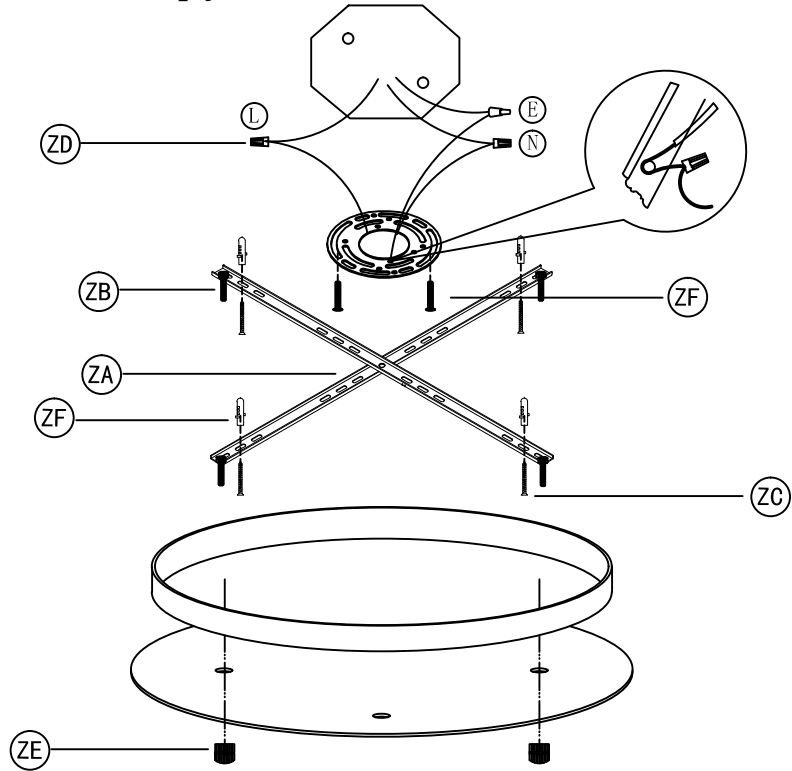

1. Drill two holes on the ceiling and put the plastic anchor screw into the holes (If the wall is wood made, this step can be ignored);
2. Attach the Bracket (ZA) to the Junction Box with two screws (ZF). Fix (ZA) on the wall with screw (ZC);
3. Connect the wires with electrician approved junction caps (ZD).

05

3503F26L2 D25.6" H10"

Step 3

Frame Assembly Diagram

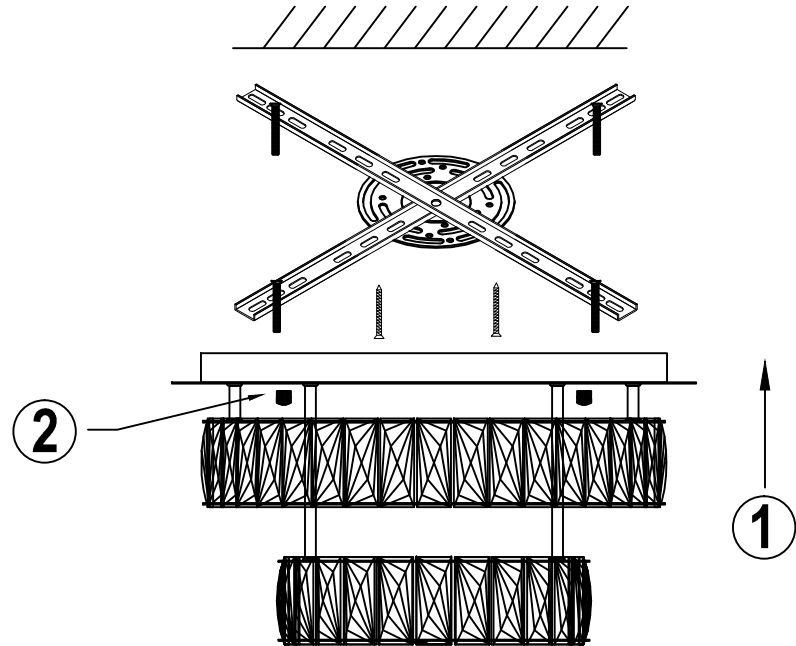

Frame Assembly Instructions

Installation:

Please read all instructions carefully, before you proceed to install. Make sure that the power supply is turned off and remained off until the installation is completed. Please note that each step has been assigned a number. Please proceed following the numerical order.

1. put the fixture on the bracket, make sure the heads of all four screws (ZB) come out from the holes on stainless steel plate (P04);
2. fix the fixture on the bracket with screw (ZE);

06

3503F26L2 D25.6" H10"

Congratulations!

You are now done installing your Elegant lighting fixture. Sit back and admire each crystal as it will become the statement piece for your room/house.

If you require any additional assistance, please contact us at 1-888-388-3390.

Thank you!

07

3503F26L2 D25.6" H10"

Cleaning and Maintenance Instruction

The frame and canopy surface is stainless polished. Please use a clean, soft and dry cloth to clean. Do not use any hard object or tools to scratch on the surface of the metal. Failure to follow these instructions automatically voids the guarantee.

Cleaning and Maintenance of Crystals

Wet a soft cotton fabric in clean warm water and wipe gently, then polish with a dry soft cotton fabric.

To Order Replacement Parts

Please contact the store where the product was purchased or contact us at the address shown on the reverse side. For ease of ordering, you may use the original parts list, indicating the model number, part number and quantity and faxing it to our customer service department at 215-423-8882. You will be contacted with prices prior to shipment. All orders must be pre-paid.

08

3503F26L2 D25.6" H10"

Elegant Lighting Warranty

The finish and frame of your new chandelier or fixture are warranted for a period of two (2) years from the date of purchase. Our company will, at its option, repair or replace any frame that has a defect in the materials or workmanship during the warranty period. All crystals are guaranteed for their original quality during the life of the chandelier. Breakage is not covered by this warranty.

To make a claim under this warranty, contact our customer service department at the address and phone number shown below. A written return authorization form will be sent to you with specific instructions.

CUSTOMER SERVICE DEPARTMENT
500-550 E. Erie Avenue
Philadelphia, PA 19134
Tel : 215-423-8880
Fax : 215-423-8882

3503F26L2 D25.6" H10"

Returns and Conditions of Warranty

Returns must be pre-authorized by contacting our customer service department at the address on the reverse side. Returns will only be accepted with a written return merchandise authorization and return shipping charges pre-paid. We reserve the right to inspect all returned merchandise to fully determine the nature of any defect. This guarantee shall not apply to any product that has been changed, altered or otherwise modified, nor shall it apply to any product that has been repaired or altered by anyone other than a pre-authorized facility. We will not be responsible for any breakage or damages incurred during transit, nor for crystal parts or metal frame part that have been subject to misuse, negligence, accident or inappropriate handling. Also, we will not be held responsible for damage incurred during improper installation or wiring by others, nor for damages resulting from a failure to follow the recommended maintenance or installation procedures. This guarantee is issued in lieu of any and all other guaranteed or warranty, whether written or implied and any and all other obligations or liabilities. Further, we neither authorize nor permit any other person or firm to assume for us, any liability in connection with the sale of our products.